

EHP-AX08EL/LM01H-P03/2832/Y/N11



High Power LED – 3 W



Data Sheet



Features

- ◆ Feature of the device: Small package with high efficiency
- ◆ Typical color temperature: 3050 K.
- ◆ Typical viewing angle: 140°
- ◆ Typical light flux output: 140 lm @700mA.
- ◆ ESD protection.
- ◆ Soldering methods: SMT
- ◆ Grouping parameter: Luminous Flux, Forward Voltage and Chromaticity.
- ◆ Optical efficiency: 52 lm/W.
- ◆ Moisture Sensitivity Level: 3
- ◆ Color rendering Index: 75 (typ.)
- ◆ Thermal resistance (Junction to Heat sink): 15 °C/W
- ◆ The product itself will remain within RoHS compliant.

Applications

- ◆ Design and effect illumination
- ◆ Interior automotive lighting (e.g. dashboard backlighting)
- ◆ Room lighting (e.g. luminaries, spotlights)
- ◆ Reading light (aircraft, car, bus)
- ◆ Signal and symbol luminaries
- ◆ Marker lights (e.g. steps, exit ways, etc.)
- ◆ Architectural illumination

Materials

Items	Description
Housing black body	Heat resistant polymer
Encapsulating Resin	Silicone resin
Electrodes	Au plating copper alloy
Die attach	Silver paste
Chip	InGaN

EHP-AX08EL/LM01H-P03/2832/Y/N11

High Power LED – 3 W



Dimensions

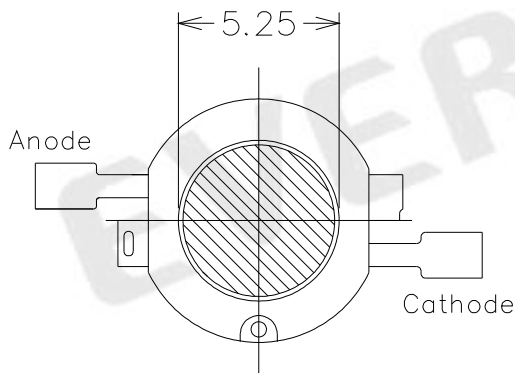
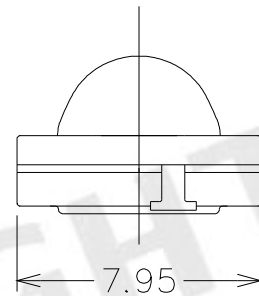
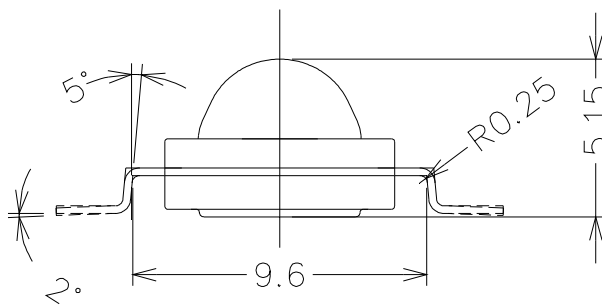
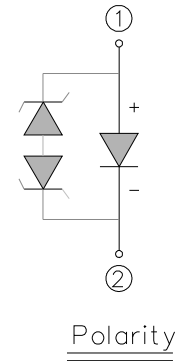
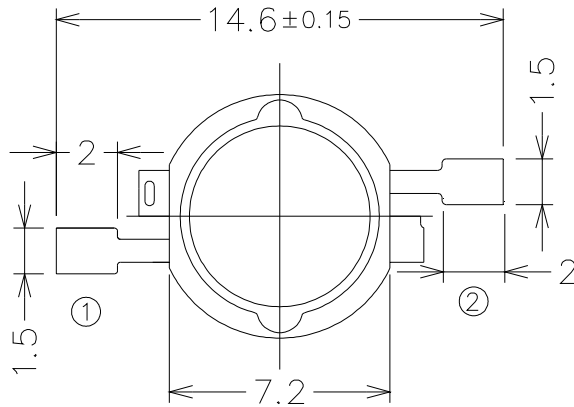

Bot. view

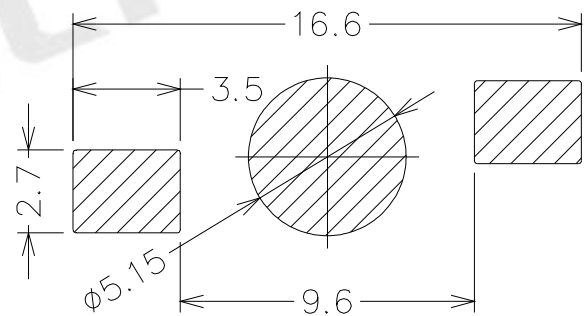

Soldering patterns

Notes.

1. Dimensions are in millimeters.
2. Tolerances for fixed dimensions are $\pm 0.25\text{mm}$.

EHP-AX08EL/LM01H-P03/2832/Y/N11

High Power LED – 3 W



Maximum Ratings ($T_{Soldering} = 25^{\circ}C$)

Parameter	Symbol	Rating	Unit
DC Operating Current	I_F	750	mA
Pulsed Forward Current ⁽¹⁾	I_{PF}	1000	mA
ESD Sensitivity	ESD	2000	V
Junction Temperature	T_j	125	$^{\circ}C$
Operating Temperature	$T_{op.}$	-40 ~ +85	$^{\circ}C$
Storage Temperature	$T_{stge.}$	-40 ~ +100	$^{\circ}C$
Junction To Heat-Sink Thermal Resistance	R_{th}	15	$^{\circ}C/W$

Electro-Optical Characteristics ($T_{Soldering} = 25^{\circ}C$)

Parameter	Bin	Symbol	Min	Typ.	Max	Unit	Condition
Luminous Flux ⁽²⁾	----	Φ_v	130	140	----	lm	$I_F=700mA$
Forward Voltage ⁽³⁾	V2	V_F	3.25	----	3.55	V	
	V3		3.55	----	3.85		
	V4		3.85	----	4.15		
	V5		4.15	----	4.45		
Color Temperature	----	CCT	2850	3050	3250	K	
Color Rendering Index ⁽⁴⁾	----	CRI	----	75	----	----	

Note.

1. t_p 100 μs , Duty cycle = 0.25
2. Luminous Flux measurement tolerance: $\pm 10\%$.
3. Forward Voltage measurement tolerance: $\pm 0.1V$.
4. Color Rendering Index measurement tolerance: ± 5

Luminous Flux Bin Table

Group	Bin	Min	Typ.	Max
E	1	1.5	----	3
	2	3	----	4
	3	4	----	5
	4	5	----	6
	5	6	----	8
F	1	8	----	10
	2	10	----	13
	3	13	----	17
	4	17	----	20
	5	20	----	23
J	1	23	----	27
	2	27	----	33
	3	33	----	39
	4	39	----	45
	5	45	----	52
K	1	52	----	60
	2	60	----	70
	31	70	----	75
	32	75	----	80
	33	80	----	85
	41	85	----	90
	42	90	----	95
	43	95	----	100
	51	100	----	110
	52	110	----	120
	53	120	----	130

Group	Bin	Min	Typ.	Max
N	11	130	----	140
	12	140	----	150
	13	150	----	160
	21	160	----	180
	22	180	----	200
	31	200	----	225
	32	225	----	250
	41	250	----	275
	42	275	----	300
	51	300	----	350
R	52	350	----	400
	1	400	----	500
	2	500	----	600
	3	600	----	750
	4	750	----	1000
	5	1000	----	1300

White Binning Structure
Warm White

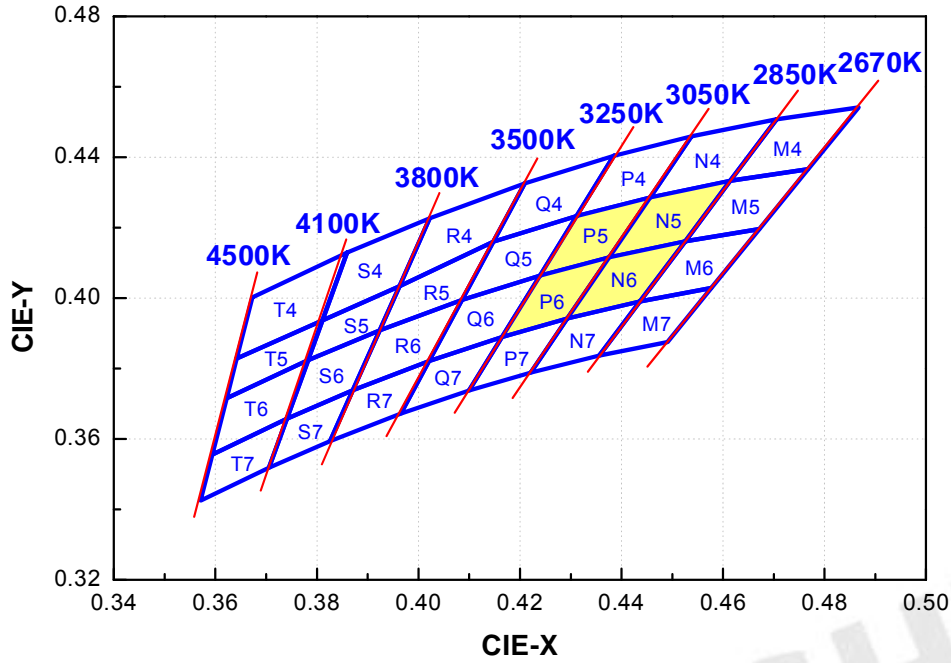

Note. The highlighted portion represents the allotted CCT sub-bins for this specific part number

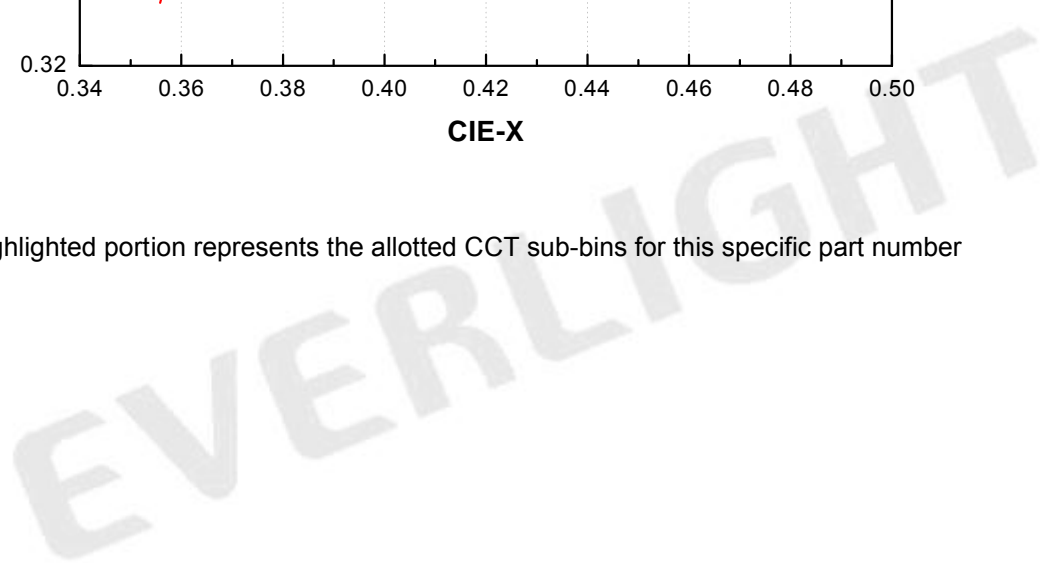

Warm -White Bin Coordinates

2628

Bin	CIE X	CIE Y
M4	0.471	0.451
	0.487	0.454
	0.477	0.437
	0.461	0.433
Reference Range: 2670~2850K		

Bin	CIE X	CIE Y
M5	0.461	0.461
	0.477	0.477
	0.467	0.467
	0.453	0.453
Reference Range: 2670~2850K		

Bin	CIE X	CIE Y
M6	0.453	0.416
	0.467	0.420
	0.458	0.403
	0.444	0.399
Reference Range: 2670~2850K		

Bin	CIE X	CIE Y
M7	0.444	0.399
	0.458	0.403
	0.449	0.388
	0.436	0.384
Reference Range: 2670~2850K		

2830

Bin	CIE X	CIE Y
N4	0.454	0.446
	0.471	0.451
	0.461	0.433
	0.446	0.429
Reference Range: 2850~3050K		

Bin	CIE X	CIE Y
N5	0.446	0.429
	0.461	0.433
	0.453	0.416
	0.438	0.412
Reference Range: 2850~3050K		

Bin	CIE X	CIE Y
N6	0.438	0.412
	0.453	0.416
	0.444	0.399
	0.429	0.394
Reference Range: 2850~3050K		

Bin	CIE X	CIE Y
N7	0.429	0.394
	0.444	0.399
	0.436	0.384
	0.422	0.379
Reference Range: 2850~3050K		

3032

Bin	CIE X	CIE Y
P4	0.438	0.440
	0.454	0.446
	0.446	0.429
	0.431	0.423
Reference Range: 3050~3250K		

Bin	CIE X	CIE Y
P5	0.431	0.423
	0.446	0.429
	0.438	0.412
	0.424	0.406
Reference Range: 3050~3250K		

Bin	CIE X	CIE Y
P6	0.424	0.406
	0.438	0.412
	0.429	0.394
	0.416	0.389
Reference Range: 3050~3250K		

Bin	CIE X	CIE Y
P7	0.416	0.389
	0.429	0.394
	0.422	0.379
	0.410	0.374
Reference Range: 3050~3250K		

EHP-AX08EL/LM01H-P03/2832/Y/N11

High Power LED – 3 W



3235

Bin	CIE X	CIE Y
Q4	0.421	0.433
	0.438	0.440
	0.431	0.423
	0.415	0.416
Reference Range: 3250~3500K		

Bin	CIE X	CIE Y
Q5	0.415	0.416
	0.431	0.423
	0.424	0.406
	0.409	0.400
Reference Range: 3250~3500K		

Bin	CIE X	CIE Y
Q6	0.409	0.400
	0.424	0.406
	0.416	0.389
	0.402	0.382
Reference Range: 3250~3500K		

Bin	CIE X	CIE Y
Q7	0.402	0.382
	0.416	0.389
	0.410	0.374
	0.397	0.367
Reference Range: 3250~3500K		

3538

Bin	CIE X	CIE Y
R4	0.402	0.423
	0.421	0.433
	0.415	0.416
	0.396	0.404
Reference Range: 3500~3800K		

Bin	CIE X	CIE Y
R5	0.396	0.404
	0.415	0.416
	0.409	0.400
	0.392	0.391
Reference Range: 3500~3800K		

Bin	CIE X	CIE Y
R6	0.392	0.391
	0.409	0.400
	0.402	0.382
	0.387	0.374
Reference Range: 3500~3800K		

Bin	CIE X	CIE Y
R7	0.387	0.374
	0.402	0.382
	0.397	0.367
	0.383	0.360
Reference Range: 3500~3800K		

3841

Bin	CIE X	CIE Y
S4	0.386	0.413
	0.402	0.423
	0.396	0.404
	0.381	0.394
Reference Range: 3800~4100K		

Bin	CIE X	CIE Y
S5	0.381	0.394
	0.396	0.404
	0.392	0.391
	0.378	0.382
Reference Range: 3800~4100K		

Bin	CIE X	CIE Y
S6	0.378	0.382
	0.392	0.391
	0.387	0.374
	0.374	0.366
Reference Range: 3800~4100K		

Bin	CIE X	CIE Y
S7	0.374	0.366
	0.387	0.374
	0.383	0.360
	0.371	0.352
Reference Range: 3800~4100K		

EHP-AX08EL/LM01H-P03/2832/Y/N11

High Power LED – 3 W



4145

Bin	CIE X	CIE Y
T4	0.367	0.400
	0.386	0.413
	0.381	0.394
	0.364	0.383
Reference Range: 4100~4500K		

Bin	CIE X	CIE Y
T5	0.364	0.383
	0.381	0.394
	0.378	0.382
	0.362	0.372
Reference Range: 4100~4500K		

Bin	CIE X	CIE Y
T6	0.362	0.372
	0.378	0.382
	0.374	0.366
	0.359	0.356
Reference Range: 4100~4500K		

Bin	CIE X	CIE Y
T7	0.359	0.356
	0.374	0.366
	0.371	0.352
	0.357	0.343
Reference Range: 4100~4500K		

Note.

1. X, Y color coordinates measurement tolerance: ± 0.01 .



Typical Electro-Optical Characteristics Curves

Relative Spectral Distribution,
 $I_F=700\text{mA}$, $T_{\text{Soldering}}=25^\circ\text{C}$

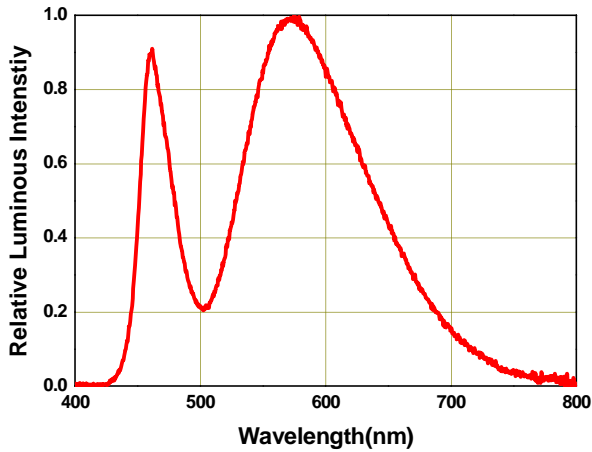

Forward Voltage vs. Forward Current,
 $T_{\text{Soldering}}=25^\circ\text{C}$

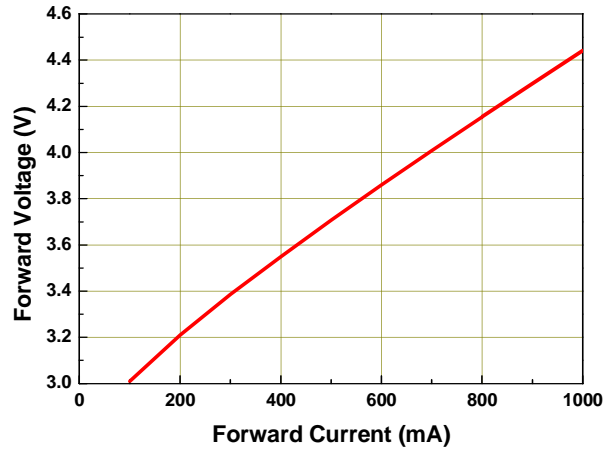

Relative Luminous Intensity vs. Forward Current, $T_{\text{Soldering}}=25^\circ\text{C}$

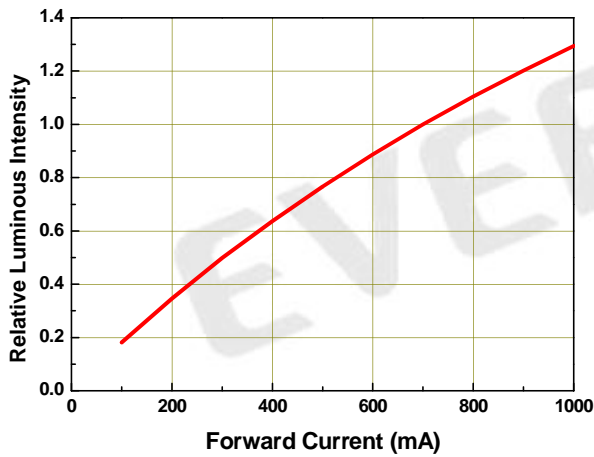

Forward Current Derating Curve,
Derating based on $T_{\text{JMAX}}=125^\circ\text{C}$

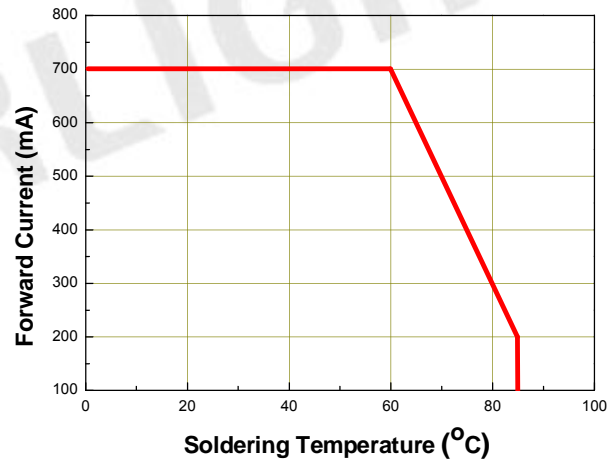

Typical Representative Spatial Radiation Pattern

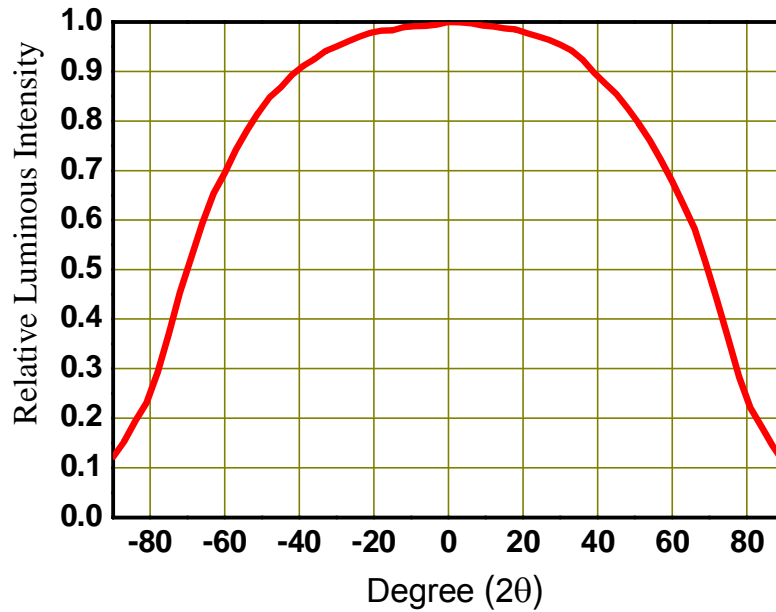

Note.

1. $2\theta_{1/2}$ is the off axis angle from lamp centerline where the luminous intensity is 1/2 of the peak value.
2. Viewing angle tolerance is $\pm 10^\circ$.

EVERLIGHT

EHP-AX08EL/LM01H-P03/2832/Y/N11

High Power LED – 3 W



Label explanation

CPN: Customer's Production Number

P/N : Production Number

QTY: Packing Quantity

CAT: Rank of Luminous Flux

HUE: Color Rank

REF: Rank of Forward Voltage

LOT No: Lot Number

MADE IN TAIWAN: Production Place



Tube Packing Specifications

1. Tube

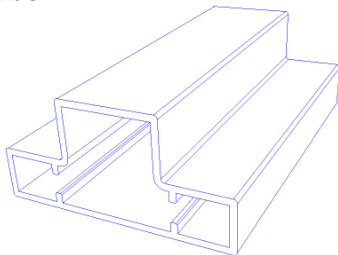

2. Inner Carton

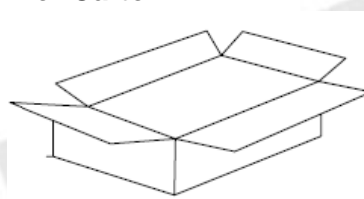

3. Outside Carton

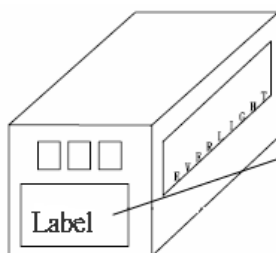

- **Packing Quantity**
 1. 50 Pcs / Per Tube
 2. 20 Tubes / Inner Carton
 3. 12 Inner Cartons / Outside Carton



Reliability Data

Stress Test	Stress Condition	Stress Duration
Reflow	Tsol=260 , 10sec, 6min	3 times
Thermal Shock	H : + 100 20min. ┆ 10sec. L : - 10 20min.	300 Cycles
Temperature Cycle	H : + 85 30min. ┆ 5min. L : - 40 30min.	300 Cycles
High Temperature/Humidity Operation	Ta=85 , RH=60%, IF=500mA	1000hours
Room Temperature Operation Life	Ta=25 , IF=700mA	1000hours
High Temperature Operation Life #1	Ta=55 , IF=600mA	1000hours
High Temperature Operation Life #2	Ta=85 , IF=500mA	1000hours
Low Temperature Operation Life	Ta=-40 , IF=700mA	1000hours

Failure Criteria:

1. LEDs are open or shorted
2. Im: luminous flux attenuate difference(1000hrs)>50%
3. VF: forward voltage difference(1000hrs)>20%

Precautions For Use

Over-current-proof

Although the EHP-AX08 series has a conductive ESD protection mechanism, customer must not use the device in reverse and should apply resistors for extra protection. Otherwise, slight voltage shifts may cause significant current change resulting in burn out failure.

1. Storage

- i. Do not open the packaging bag before the devices are ready to use.
- ii. Before the package is opened, LEDs should be stored at temperatures less than 30 and humidity less than 50%.
- iii. LEDs may be stored for 6 months. When the storage time has reached more than 6 months, LEDs should be stored in a sealed container filled with the Nitrogen gas.
- iv. After the package is opened, LEDs should be stored at temperatures less than 30 and humidity less than 30%.
- v. LEDs should be used within 168 hours (7 days) after the package is opened.
- vi. Before using LEDs, baking treatment should be implemented based on the following conditions: pre-curing at 60±5 for 24 hours.

2. Thermal Management

- i. For maintaining the high flux output and achieving maximum reliability, EHP-AX08 series LEDs should be mounted on a metal core printed circuit board (MCPCB) or other kinds of heat sink with proper thermal connection to dissipate approximately 3W of thermal energy at 700mA operation.
- ii. Heat dissipation or thermal conduction design is strongly recommended on PCB or MCPCB for reflow soldering purposes. Please refer to soldering patterns on Page 2.
- iii. Sufficient thermal management must be implemented. Please refer to the graph "Forward Current Derating Curve " on Page 9. The soldering temperature must be kept under 60 at the driving current 700mA. Otherwise, the junction temperature of die may exceed over the limit at high current driving conditions and the LEDs' lifetime may be decrease dramatically.
- iv. Special thermal designs are also recommended to take in outer heat sink design, such as FR4 PCB on Aluminum with thermal vias or FPC on Aluminum with thermal conductive adhesive, etc.
- v. Sufficient thermal management must be conducted, or the die junction temperature will be over the limit under large electronic driving and LED lifetime will decrease critically.

3. Proper Handling

To avoid contamination of materials, damage of internal components, and shortening of LED lifetime, do not subject LEDs to conditions as those listed below.

Bare Hand

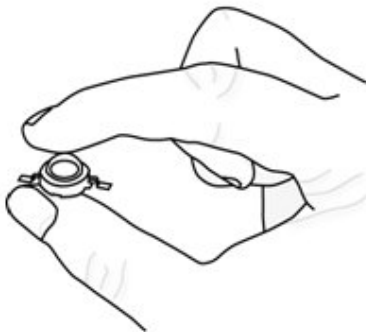

When handling the product, do not apply direct pressure on the resin.

Tweezers

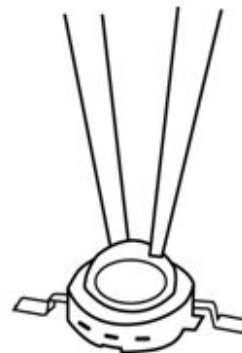

Do not touch the resin to avoid scratching or other damage.

Pick and Place Nozzle for Surface Mount Assembly.

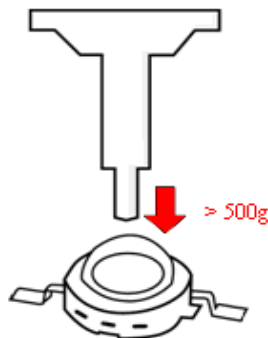

Avoid directly contacting the lens with downward force of more than 500g.

During Module Assembly

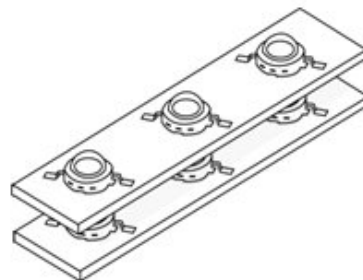

Do not stack the modules together, it could damage the resin or scratch the lens.

EHP-AX08EL/LM01H-P03/2832/Y/N11

High Power LED – 3 W



During Module Assembly

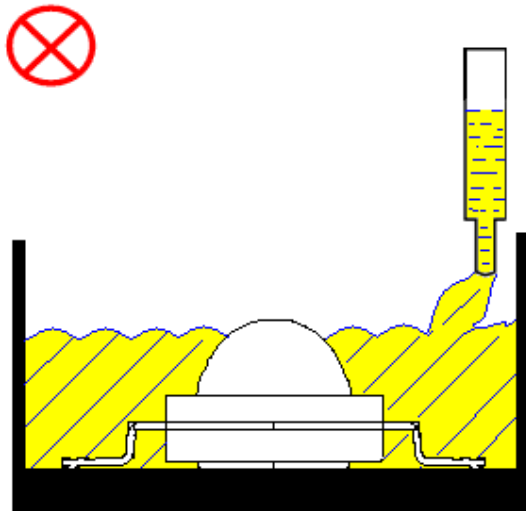

Sealing process with water-proof silicone is not suitable for EHP-AX08 Products.

EVERLIGHT

4. Soldering Iron

i. For Reflow Process

- a. EHP-AX08 series are suitable for SMT process.
- b. Curing of glue in oven according to standard operation flow processes.

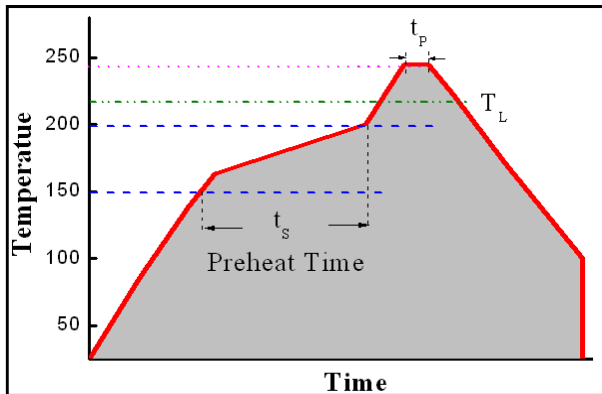

Profile Feature	Lead Free Assembly
Ramp-Up Rate	2-3 °C/S
Preheat Temperature	150-200 °C
Preheat Time (ts)	60-120 S
Liquid Temperature (TL)	217 °C
Time maintained above TL	60-90 S
Peak Temperature (Tp)	240±5 °C
Peak Time (tp)	Max 20 S
Ramp-Down Rate	3-5 °C/S

- c. Reflow soldering should not be done more than twice.
- d. In soldering process, stress on the LEDs during heating should be avoided.
- e. After soldering, do not warp the circuit board.

ii. For Manual Soldering Process

- a. For prototype builds or small series production runs it is possible to place and solder the LED by hand.
- b. Dispense thermal conductive glue or grease on the substrates and follow its curing specifications. Gently press LED housing to closely connect LED and substrate.
- c. It is recommended to hand solder the leads with a solder tip temperature of 280°C for less than 3 second, at a time with a soldering iron of less than 25W. Solder at intervals of two seconds or more.
- d. Take caution and be aware that damaged products are often a result of improper hand soldering technique.

EHP-AX08EL/LM01H-P03/2832/Y/N11

High Power LED – 3 W



Revision History

Page	Subjects(major change in previous version)	Date of change
14	Change Proper Handling	2010/08/12

■ Prepared date:	12-Aug-2010	■ Device No.:	DHE-0001186
■ Created by:	Iris Yeh	■ Rev.:	2

For product information and a complete list of distributors, please go to our web site : www.everlight.com

Everlight Electronics Co., Ltd. and the logo are trademarks of Everlight Electronics Co., Ltd. in the Taiwan and other countries. Data subject to change.

Copyright © 2005-2009 Everlight Electronics Co., Ltd.. All rights reserved.